

## **DOUBLE-EFFECT EVAPORATOR WITH SCRAPER**

### **STEAM HEATED**

**Model WT 500 HS-R 2E Titanium**

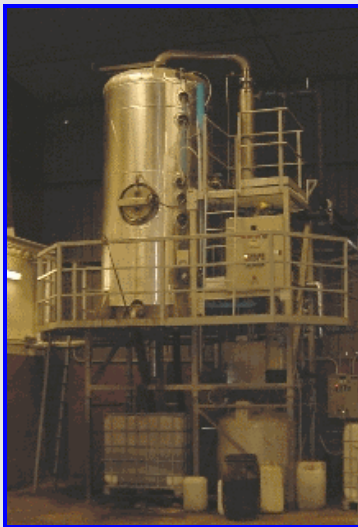

#### ***General description***

The machine is constructed as a double-effect evaporator, realised in a single unit.

This solution permits the reduction of the energy consumption with about 50% and also permits a simplified installation.

The machine uses steam as a heating source, to be supplied by the user.

The installed heating power is 175.000 kcal/h.

The condensation system is a vertical tube water-cooled condenser.

Both the first and the second effect are equipped with a specially designed scraper that permits a high concentration of the contaminants, avoiding the necessity of cleaning the heating surfaces manually.

The control instruments are selected with great care and include:

- vibrating level control
- maximum temperature thermostat
- thermostat on the vacuum system
- vacuum switch
- amperometric control and overload control on the motors

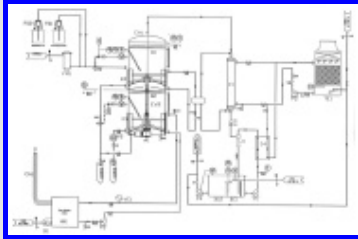

#### Technical data

Evaporated water	kg/h	500
Energy needed per kg evaporated water	kcal/h	350
Heating steam flow (0,9 bar)	kg/h	312
Installed heating power	kcal/h	175.000
Cooling water flow (T in = 25° C - T out = 30° C)	m <sup>3</sup> /h	35
Compressed air consumption 6 bar	m <sup>3</sup> /h	0,5
Installed electrical power	kW	7
Absorbed electrical power	kW	6

#### Consistency of the offer

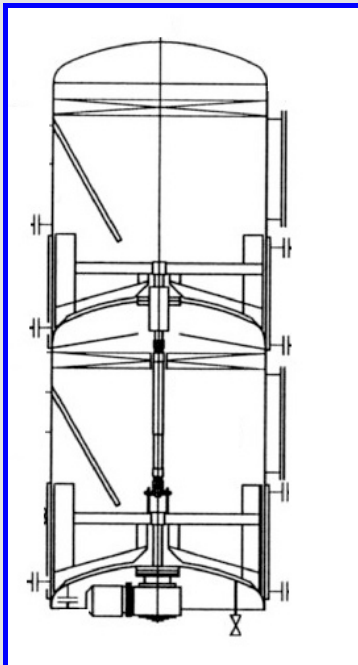

N° 1 double body evaporator in titanium (material in contact with the liquid to be treated), equipped with a special designed scraper system with motorreducer. Both evaporation chambers with manhole or removable cover for easy inspection and maintenance.

N° 2 demisters in PVC.

N° 1 mechanical filter on the loading line with a mesh of 0,5 mm



Pneumatic valves for the automatic loading of the liquid to be treated and for the unloading of both residue and distillate.

N° 2 level control groups, with vibration element.



N° 1 centrifugal pump with venturi jet for the vacuum creation, complete with vessel for the separation gas/liquid in stainless steel.

N° 1 extraction pump for the condensate with magnetic level control.



N° 1 vertical-tube condenser in stainless steel AISI 304, for the condensation of the vapours of the top evaporator.

N° 1 auxiliary heat-exchanger in AISI 304 for the separate cooling of the vacuum group.



**Optional**



Boiler

Hot water boiler, equipped with methane burner, for 175.000 kcal/h  
Further specification on request.



Cooling tower

Cooling tower (175.000 kcal/h)  
Further specification on request.



**Sawyer and Smith Corporation**

5412 Homegardner Road

Castalia, Ohio 44824

Ph: 419.951.4818

Fax: 419.951.4822

[sales@wastewaterevaporators.biz](mailto:sales@wastewaterevaporators.biz)

[www.wastewaterevaporators.biz](http://www.wastewaterevaporators.biz)

March 1, 2010

Contact information update:

We have begun the long arduous process of moving our office.  
Please continue to direct mail to:

Sawyer and Smith Corporation  
5412 Homegardner Road  
Castalia, Ohio 44824

All phone contact to:  
423.289.6894

All other email and website information remains the same. You can contact us at any of the existing web addresses. Email is received remotely and responded to more quickly and efficiently than a phone message. If you call the office, please leave a thorough message INCLUDING your email address so that we can send you the required information as soon as possible.

Thank You.